

**SPECIFICATIONS:**

- **FREQUENCY:** . . . . . 0.5 GHz TO 18 GHz
- **INSERTION LOSS:** . . . . . REFLECTIVE: 3.25db  
 ABSORPTIVE: 4.0db
- **ISOLATION:** . . . . . 0.5 GHz TO 2 GHz: 60db  
 2 GHz TO 18 GHz: 70db
- **VSWR:** . . . . . REFLECTIVE IN/OUT: 2.0:1  
 ABSORPTIVE IN/OUT: 2.0:1  
 ABSORPTIVE OUT/OFF: 2.0:1
- **SPEED:** . . . . . RISE: 10ns TYPICAL, 15ns MAX.  
 FALL: 10ns TYPICAL, 15ns MAX.  
 DELAY ON: 75ns TYPICAL, 100ns MAX.  
 DELAY OFF: 75ns TYPICAL, 100ns MAX.
- **POWER INPUT:** . . . . . (CW)+20dBm (STANDARD), +10 dBm (HIGH SPEED)
- **SURVIVAL POWER:** . . . . . -1 WATT CW, 10 WATTS PEAK 1 usec
- **CONTROL:** . . . . . TTL LOGIC "0"=ON "1"=OFF
- **POWER SUPPLY:** . . . . . +5V @ 250 mA MAX.  
 -5V @ 75mA MAX.(RELECTIVE)  
 100mA MAX.(ABSORPTIVE/NON-REFLECTIVE)

**OPTIONS:**

- INDEPENDENT CONTROL WITH SOLDER PIN STANDARD
- DEC-SR . . . . . 3 BIT DECODER WITH SOLDER PIN
- 10M18 . . . . . 10 MHz TO 18 GHz (INSERTION LOSS INCREASES BY 1.5db AT 10 MHz AND 0.5db AT 18 GHz)
- 100M18 . . . . . 100 MHz TO 18 GHz (INSERTION LOSS INCREASES BY 1.5db AT 100 MHz AND 0.5db AT 18 GHz)
- 118 . . . . . 1 GHz TO 18 GHz (NO CHANGE IN INSERTION LOSS)
- 218 . . . . . 2 GHz TO 18 GHz (NO CHANGE IN INSERTION LOSS)
- 412 . . . . . 4 GHz TO 12.4 GHz (NO CHANGE IN INSERTION LOSS)
- 818 . . . . . 8 GHz TO 18 GHz (NO CHANGE IN INSERTION LOSS)
- 1218 . . . . . 12 GHz TO 18 GHz (NO CHANGE IN INSERTION LOSS)
- 100M20 . . . . . 100 MHz TO 20 GHz (INSERTION LOSS INCREASES BY 1.5db AT 100 MHz AND 0.5db AT 20 GHz)
- 220 . . . . . 2 GHz TO 20 GHz (INSERTION LOSS INCREASES BY 1.0db AT 20 GHz)
- 1020 . . . . . 10 GHz TO 20 GHz (INSERTION LOSS INCREASES BY 1.0db AT 20 GHz)
- B01 . . . . . -12V POWER SUPPLIES
- B02 . . . . . -15V POWER SUPPLIES
- B03 . . . . . REVERSE LOGIC "1"=ON "0"=OFF
- B04 . . . . . DRIVERLESS, CURRENT CONTROLLED
- B05 . . . . . HIGH SPEED, TURNON/TURNOFF 25 nsec MAXIMUM WHEN APPLICABLE
- B08 . . . . . HIGH POWER - SPECIFY CW POWER, PEAK POWER, PULSE WIDTH, DUTY CYCLE, RF FREQUENCY AND BANDWIDTH
- B07 . . . . . CUSTOM DESIGNED PRODUCT- SPECIFY INITIALS OF CUSTOMER
- B08 . . . . . LOW VIDEO TRANSIENTS - SPECIFY VIDEO BANDWIDTH
- B09 . . . . . LOW INSERTION LOSS VERSION
- B10 . . . . . HIGHER ISOLATION VERSION
- B11 . . . . . 0.40" THICK VERSION
- B12 . . . . . 0.70" THICK VERSION

**ENVIRONMENTAL RATINGS:**

- **TEMPERATURE:** . . . . . -55°C TO +85°C (OPERATING)  
 -65°C TO +125°C (STORAGE)
- **HUMIDITY:** . . . . . MIL-STD-202F, METHOD 103B COND. B
- **SHOCK:** . . . . . MIL-STD-202F, METHOD 213B COND. B
- **VIBRATION:** . . . . . MIL-STD-202F, METHOD 204D COND. B
- **ALTITUDE:** . . . . . MIL-STD-202F, METHOD 105C COND. B
- **TEMPERATURE CYCLE:** . . . . . MIL-STD-202F, METHOD 107D COND. A

ALL DIMENSIONS ARE IN INCHES  
 TOLERANCES:

- X.XX ±0.020
- X.XXX ±0.010

REV.		DESCRIPTION	DATE	APPROVED
ZONE	REV.			
	A	ORIGINAL RELEASE	8/11/97	

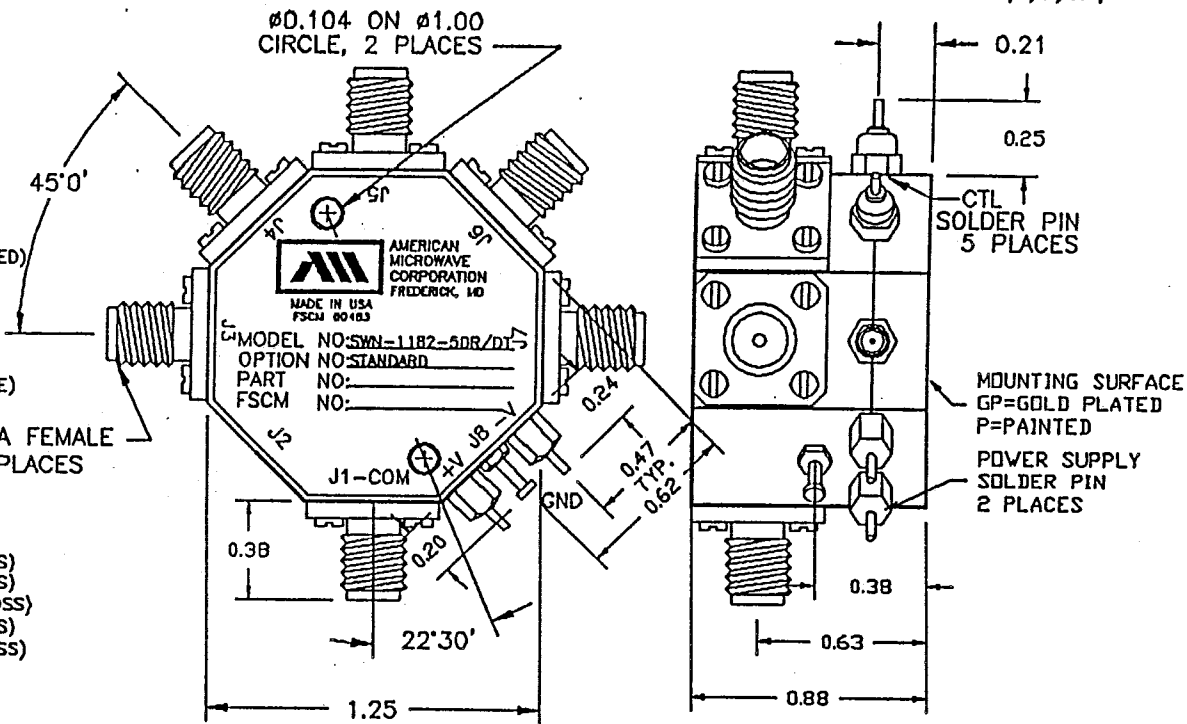

NOTE:  
 DR=WITH DRIVER, REFLECTIVE  
 DT=WITH DRIVER, NON-REFLECTIVE/ABSORPTIVE

CONTRACT NO.		AMERICAN MICROWAVE CORPORATION FREDERICK, MARYLAND	
APPROVALS	DATE	TITLE	
DRAWN	8/11/97	OUTLINE DRAWING	
CHECKED	11/7/97	SWN-1182-5DR/DT-STANDARD	
ISSUED		REFLECTIVE OR NON-REFLECTIVE/ABSORPTIVE RADIAL SOLID STATE SWITCH	
SIZE	FSCM NO.	DWG NO.	REV.
A	60483	100-4103-1	A
SCALE N/S		1 of 1	

NOTE: THE SPECIFICATIONS ARE SUBJECT TO CHANGE OR REVISION

13-1